

Wiring diagram

❖ 4. Wiring diagram

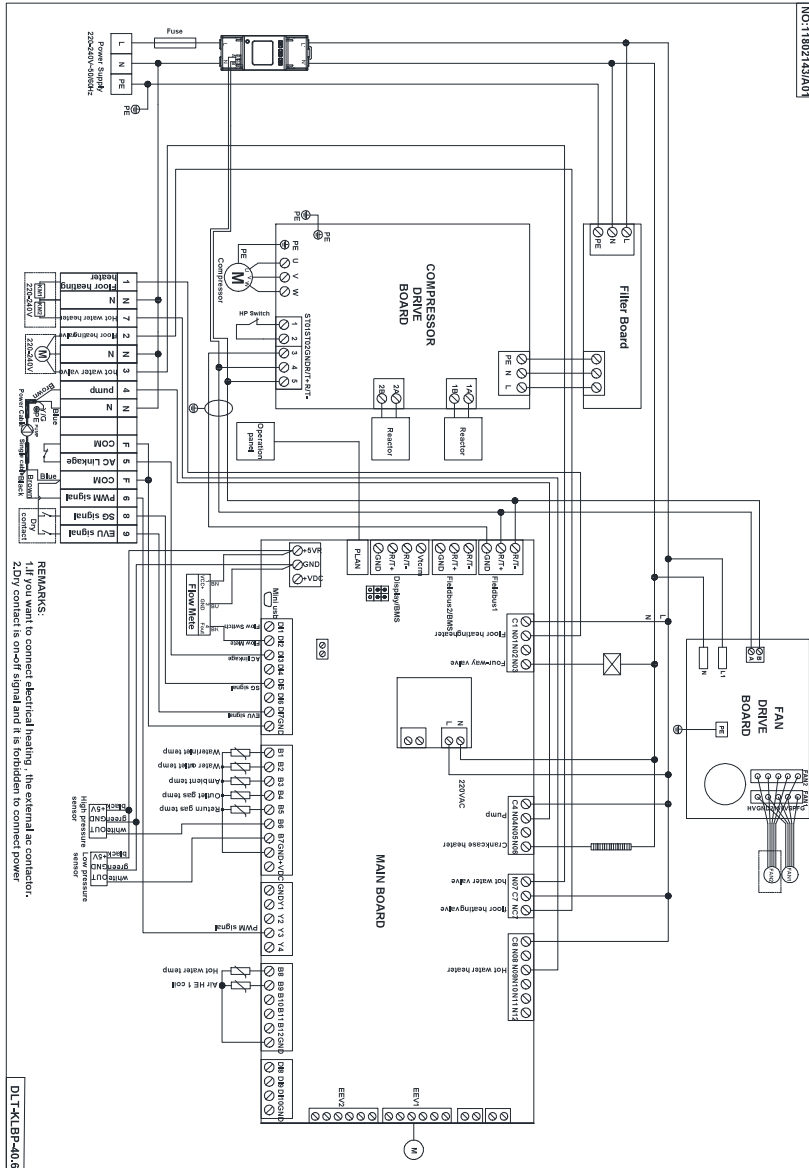

Voltage: 220V-240V/50Hz

